

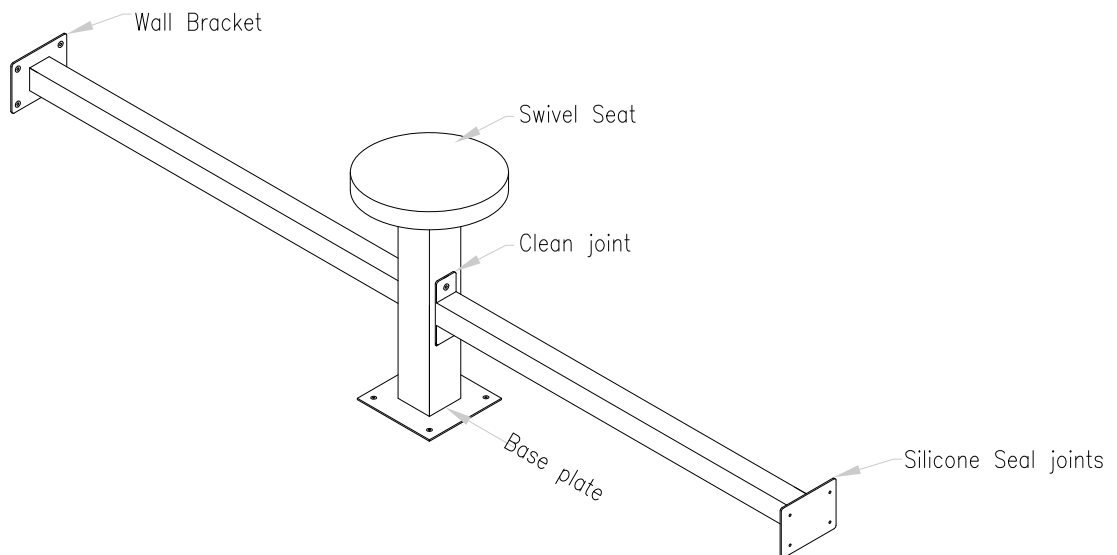

Cleanroom Stainless Steel Step Over Barrier

- ✔ Free area below barrier for good air scavange
- ✔ 316 or 304 stainless steel option
- ✔ Swivel seat
- ✔ Low lift leg swing due to low barrier
- ✔ Suitable for any width change room
- ✔ Additional swivel seats (1200mm between centres)
- ✔ Strong wall brackets for all types of wall construction
- ✔ Suitable for all cleanroom change areas wet or dry
- ✔ Removable section for wheeled access
- ✔ Disabled access option



All technickon products are manufactured and tested prior to dispatch and are covered by a 12 month warranty from the dispatch date. Full operation and maintenance instructions are supplied as standard with all technickon products. If you require assistance in selecting the best equipment to suit your requirement please do not hesitate to contact us