

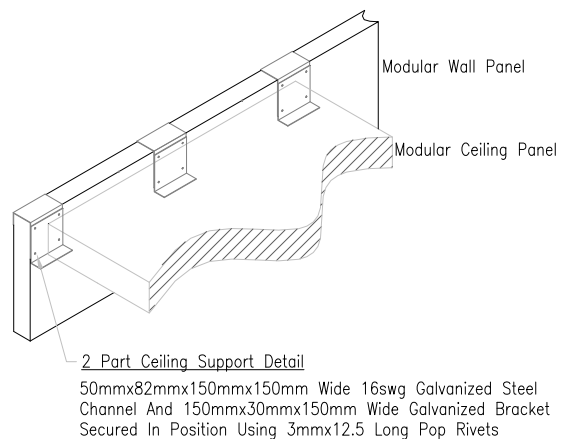

Cleanroom Modular Wall and Ceiling Panels

- Modular panel 1160mm (W) x varying length
- White finished steel facing to both sides
- PU, Rockwool or aluminium core
- Installation of sockets or services
- On site panel repair
- Full range of trims and liners available
- Resistant to most cleaning products
- AutoCAD drawings provided
- 50mm, 75mm, 100mm, 120mm wall thickness
- Pre formed apertures within walls and ceilings
- Easy and quick installation
- Silicone sealed T & G panel joint
- Walk on ceiling panels for access

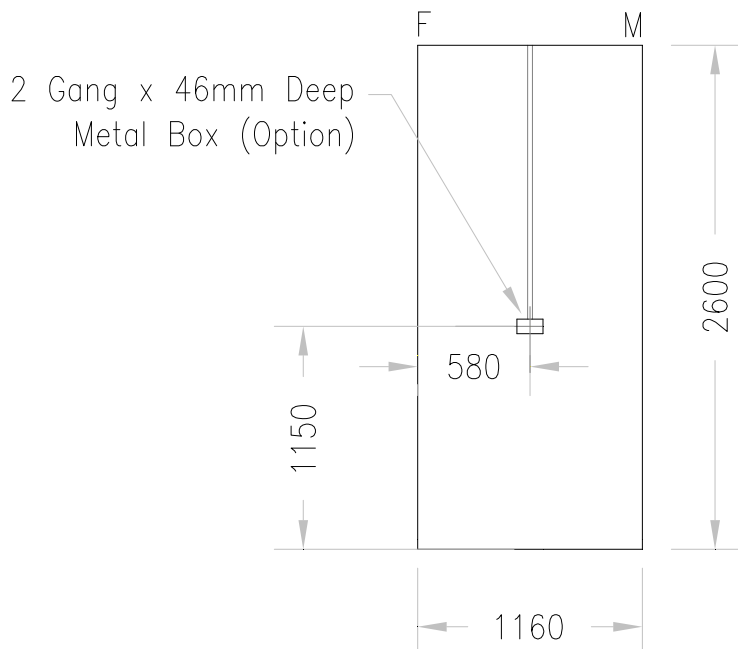

All technickon products are manufactured and tested prior to dispatch and are covered by a 12 month warranty from the dispatch date. Full operation and maintenance instructions are supplied as standard with all technickon products. If you require assistance in selecting the best equipment to suit your requirement please do not hesitate to contact us